

# SHARP SERVICE MANUAL

CODE: 00ZPC1260SM/E



## PC-1261 MODEL PC-1260

### 1. SPECIFICATION

• Keyboard layout:

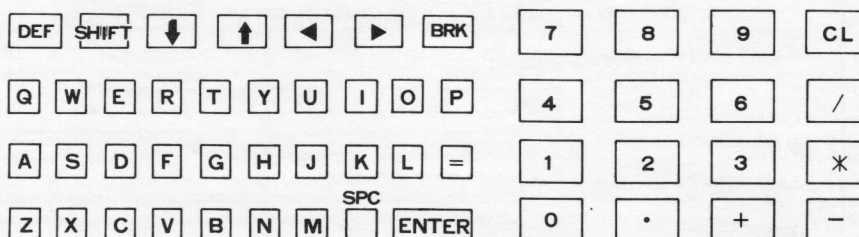

• Operational capacity:

10 digits of mantissa with two digits of exponentiation

• Computation method:

Exactly as the programmed statement (with the priority determination feature)

• Programming language:

BASIC

• CPU:

CMOS, 8-bit CPU

• System ROM:

40 KB

• Memory capacity:

System area: About 0.6 KB

Data dedicated area:

208 bytes

Program/data area:

PC-1261: 9842 bytes

PC-1260: 3198 bytes

Reserve area: 48 bytes

Statement program area

(basic capacity): 128 bytes

• Stack:

For subroutine use: 10 stacks

For FOR-NEXT statement:

5 stacks

For function: 16 stacks

For data: 8 stacks

• Basic computing functions:

Basic computation:

Four math rules

Function:

Trigonometric function, inverse trigonometric function, logarithm, exponential, angle conversion, power raising, square root extract, integer conversion, absolute value, signum function, circle ratio, etc.

• Editing function:

Horizontal cursor shift (▶, ◀)

Insertion (INS)

Deletion (DEL)

Line up and down (↓, ↑)

• Memory protection:

Battery backup to retain program, data, and reserve contents during power off

• Display:

5 x 7 dot matrix LCD (24 digits x 2 lines) (LF8223E)

Display character size:  
4.01(H) x 2.85(W) mm  
Pitch: 3.7mm

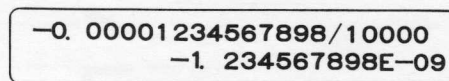
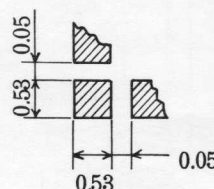

← Statement  
← Computational results displayed with exponent in use

• Auto power off:

About 11 minutes

• Operating temperature:

0 to 40°C

• Power supply:

6V  $\ddot{\cdot}$  (DC) lithium battery (CR2032) x 2

• Battery life:

Approximately 300 hours when all 24 display digits are indicated with "5" continuously under the operating temperature of 20°C.

Subject to fluctuation depending on the type of battery and usage.

• It will last about four months when used one hour per day, provided that 10 minutes are dedicated for operation or program execution and 50 minutes for displaying.

- Power consumption: 0.03 W
- Physical dimensions: 135(W) x 70(D) x 9.5(H) mm
- Weight: 115 grams including batteries
- Accessories: Hard cover, two templates, two lithium batteries inside

the unit, instruction manual,  
name label

## 2. SYSTEM BLOCK DIAGRAM

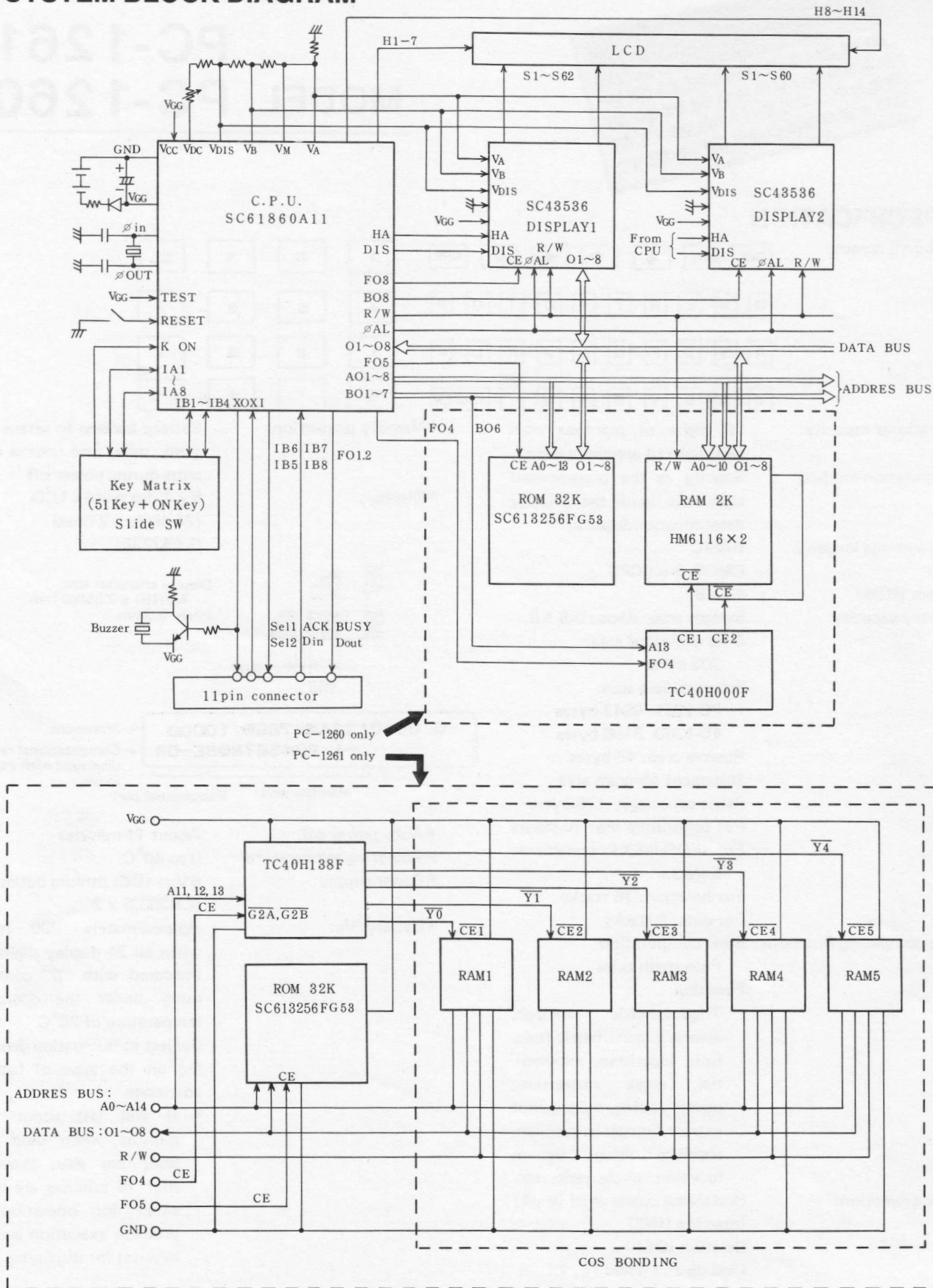



## 3. CPU SIGNAL DESCRIPTION

Pin No.	Signal Name	In/Out	Function (standby = power off)
1	AO1	Out	Address bus line, high during standby
2	R/W	Out	Write clock signal, normally high
3	$\phi$ AL	Out	Low order bit address latch, normally high. The clock used to latch the low order 8 bits of the 16-bit address signal for the data bus line, when a large capacity ROM is used.
4	TES	In	Test input, normally low
5	$\phi$ i	In	Oscillator input
6	$\phi$ o	Out	Oscillator output
7	RES	In	Reset input, normally pulled down to low level. Reset when high.
8	Xin	In	CE-125 microcassette option signal input (MTin)
9	ON	In	ON (BREAK) key input, normally pulled down to low level
10	Xout	Out	CE-125 microcassette option signal and buzzer signal output (MTout1)
11	Dis	Out	LCD driver control signal
12	HA	Out	LCD driver clock. Low during standby, and 2 kHz pulse is issued during displaying.
13	iA8	In/Out	Key input/key strobe output, normally low, but pulse issued with a key operation.
14	iA7	In/Out	Key input/key strobe output, normally low, but pulse issued with a key operation.
15	iA6	In/Out	Key input/key strobe output, normally low, but pulse issued with a key operation.
16	iA5	In/Out	Key input/key strobe output, normally low, but pulse issued with a key operation.
17	iA4	In/Out	Key input/key strobe output, normally low, but pulse issued with a key operation.
18	iA3	In/Out	Key input/key strobe output, normally low, but pulse issued with a key operation.
19	iA2	In/Out	Key input/key strobe output, normally low, but pulse issued with a key operation.
20	iA1	In/Out	Key input/key strobe output, normally low, but pulse issued with a key operation.
21	iB8	In	ACK signal which enables the I/O (PCU) to read data from the CPU.
22	iB7	In	Data in signal (Din) which is a serial data input from the PCU (bit unit, serial handshake).
23	iB6	Out	(SEL2) select output, P-type open drain
24	iB5	Out	(SEL1) select output, P-type open drain
25	iB4	In	Slide switch input
26	iB3	Out	Key strobe output, low during standby, but pulse issued with a key operation.
27	iB2	Out	Key strobe output, low during standby, but pulse issued with a key operation.
28	iB1	Out	Key strobe output, low during standby, but pulse issued with a key operation.
29	VM	In	LCD power supply
30	VA	In	LCD power supply
31	GND	In	Power supply
32	H1	Out	LCD backplate signal, high impedance during standby, but 4 level pulse issued during displaying.
33	H2	Out	LCD backplate signal, high impedance during standby, but 4 level pulse issued during displaying.
34	H3	Out	LCD backplate signal, high impedance during standby, but 4 level pulse issued during displaying.
35	H4	Out	LCD backplate signal, high impedance during standby, but 4 level pulse issued during displaying.
36	H5	Out	LCD backplate signal, high impedance during standby, but 4 level pulse issued during displaying.
37	H6	Out	LCD Backplate signal, high impedance during standby, but 4 level pulse issued during displaying.
38	H7	Out	LCD backplate signal, high impedance during standby, but 4 level pulse issued during displaying.
39	H8	Out	LCD backplate signal, high impedance during standby, but 4 level pulse issued during displaying.
40	H9	Out	LCD backplate signal, high impedance during standby, but 4 level pulse issued during displaying.

Pin No.	Signal Name	In/Out	Function (standby – power off)
41	H10	Out	LCD backplate signal, high impedance during standby, but 4 level pulse issued during displaying.
42	H11	Out	LCD backplate signal, high impedance during standby, but 4 level pulse issued during displaying.
43	H12	Out	LCD backplate signal, high impedance during standby, but 4 level pulse issued during displaying.
44	H13	Out	LCD backplate signal, high impedance during standby, but 4 level pulse issued during displaying.
45	H14	Out	LCD backplate signal, high impedance during standby, but 4 level pulse issued during displaying.
46	H15	–	Not used because the display unit of this model is operates under 1/14 duty.
47	H16	–	Not used because the display unit of this model is operates under 1/14 duty.
48	VB	In	LCD power supply, high during standby and VB when clock is at stop.
49	VDiS	In	LCD power supply, high during standby and low when clock is at stop.
50	VCC	In	LCD power supply, normally low.
51	VDC	Out	LCD power supply, high during standby and low when clock is at stop.
52	VGG	In	Power supply, normally low
53	o8	In/Out	Data bus line, normally high impedance
54	o7	In/Out	Data bus line, normally high impedance
55	o6	In/Out	Data bus line, normally high impedance
56	o5	In/Out	Data bus line, normally high impedance
57	o4	In/Out	Data bus line, normally high impedance
58	o3	In/Out	Data bus line, normally high impedance
59	o2	In/Out	Data bus line, normally high impedance
60	o1	In/Out	Data bus line, normally high impedance
61	Fo5	Out	32K ROM chip enable
62	Fo4	Out	Option RAM chip enable
63	Fo3	Out	LCD driver LSI (DISPLAY 1) chip enable
64	Fo2	Out	Data out (Dout) peripheral data out port output
65	Fo1	Out	BUSY (I/F) out port output
66	Bo8	Out	LCD driver LSI (DISPLAY 2) chip enable
67	Bo7	Out	(A14) address bus line, high during standby
68	Bo6	Out	(A13) address bus line, high during standby
69	Bo5	Out	(A12) address bus line, high during standby
70	Bo4	Out	(A11) address bus line, high during standby
71	Bo3	Out	(A10) address bus line, high during standby
72	Bo2	Out	(A9) address bus line, high during standby
73	Bo1	Out	(A8) address bus line, high during standby
74	Ao8	Out	(A7) address bus line, high during standby
75	Ao7	Out	(A6) address bus line, high during standby
76	Ao6	Out	(A5) address bus line, high during standby
77	Ao5	Out	(A4) address bus line, high during standby
78	Ao4	Out	(A3) address bus line, high during standby
79	Ao3	Out	(A2) address bus line, high during standby
80	Ao2	Out	(A1) address bus line, high during standby



## 4. LCD DRIVE AND TIMINGS

### 4-1. LCD drive LSI (SC43536)

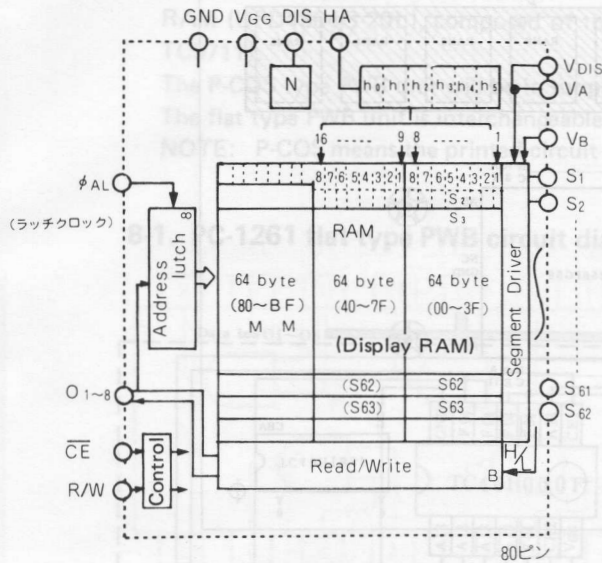

The 24-digit liquid crystal display is divided into half. H1 through H7 are used for backplate signal from the first digit to the twelfth digit, and H8 through H14 are used for backplate signal from the thirteenth digit to the twenty fourth digit. Therefore, the LCD operates under the 1/14 duty.

### 4-2. LCD timings

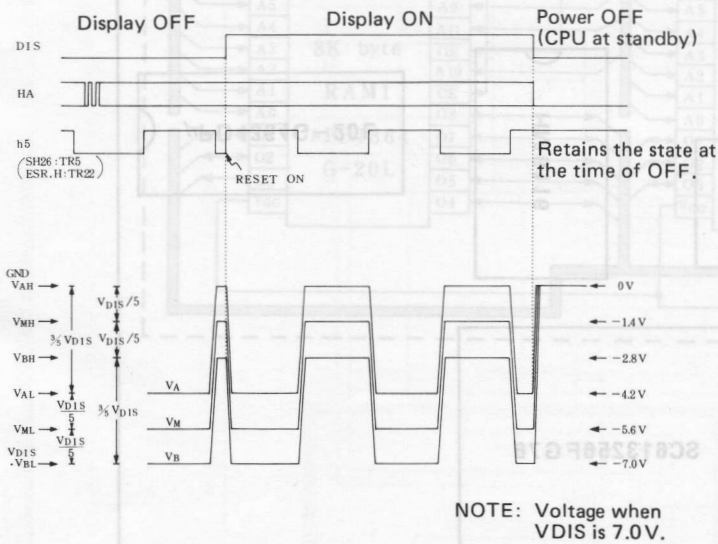

### 4-3. Counter section and segment output waveforms

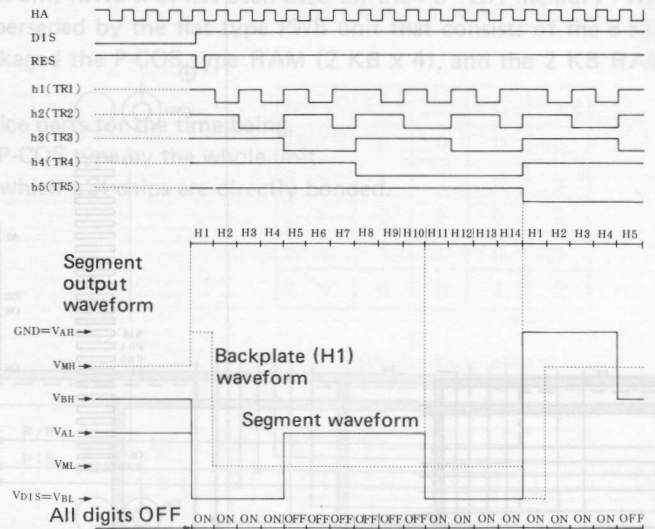

	h5 = 0	h5 = 1
All digits OFF (Dis = L)	VAL	VBH
ON	VBL	VAH
OFF	VAH	VBH

## 5. MEMORY MAP

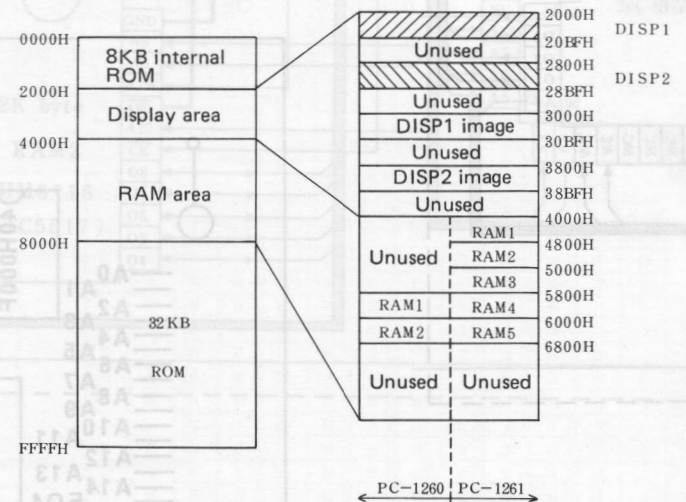

## 6. CHIP ENABLE PROGRAM LOGIC ARRAY (CE-PLA)

Address	A15	A14	A13	A12	A11
F05 (ROM)	1	×	×	×	×
F04 (RAM)	0	1	×	×	×
F03 (Disp1)	0	0	1	×	0
B08 (Disp2)	0	0	1	×	1

× : Don't Care

## 7. RAM SELECT CE-PLA

## 7-2. PC-1260 decoder (TC40H00P)

### 7-1. PC-1261 decoder (TC40H138P)

F04	A13	A12	A11	Output
0	0	0	0	RAM1
0	0	0	1	// 2
0	0	1	0	// 3
0	0	1	1	// 4
0	1	0	0	// 5

F04	A13	Output
0	0	RAM1
0	1	RAM2

Pin configuration

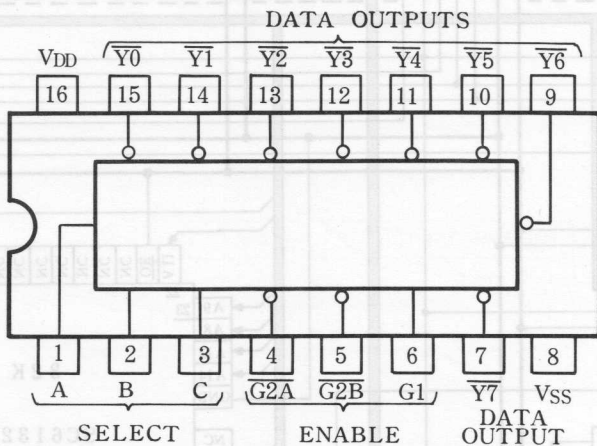

Truth table

INPUTS						OUTPUTS							
ENABLE			SELECT			Y0	Y1	Y2	Y3	Y4	Y5	Y6	Y7
G1	G2A	G2B	A	B	C								
L	*	*	*	*	*	H	H	H	H	H	H	H	H
*	H	*	*	*	*	H	H	H	H	H	H	H	H
*	*	H	*	*	*	H	H	H	H	H	H	H	H
H	L	L	L	L	L	L	H	H	H	H	H	H	H
H	L	L	H	L	L	H	L	H	H	H	H	H	H
H	L	L	L	H	L	H	H	L	H	H	H	H	H
H	L	L	H	H	L	H	H	H	L	H	H	H	H
H	L	L	L	L	H	H	H	H	H	L	H	H	H
H	L	L	H	L	H	H	H	H	H	H	L	H	H
H	L	L	L	H	H	H	H	H	H	H	L	H	H
H	L	L	H	H	H	H	H	H	H	H	H	L	H

\* : Don't care

Pin configuration

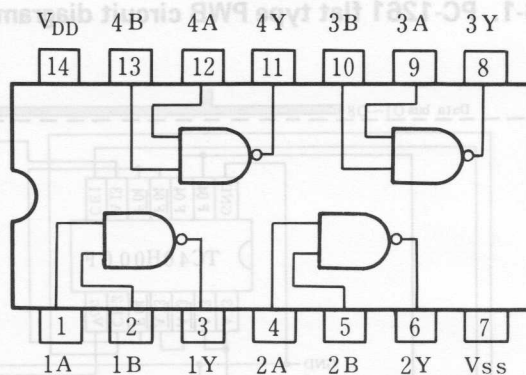

$$Y = A \cdot B$$

Truth table

Input		Output
A	B	Y
L	L	H
H	L	H
L	H	H
H	H	L



## 8. CAUTION ABOUT THE PC-1261 MEMORY PWB UNIT (P-COS AND FLAT TYPES)

Since the first production unit the P-COS type RAM unit (2KB x 5) has been used for the PC-1261 memory PWB unit. But, in some of PWB unit in future, it may be superseded by the flat type PWB unit that consists of the 8 KB flat packaged RAM (UPD4364G-20L), composed of the flat packaged the P-COS type RAM (2 KB x 4), and the 2 KB RAM (HM6116 or TC5711).

The P-COS type PWB unit will be in supply for service parts for the time being.

The flat type PWB unit is interchangeable with the P-COS type by the whole unit.

NOTE: P-COS means the printed circuit board on which LSI chips are directly bonded.

### 8-1. PC-1261 flat type PWB circuit diagram

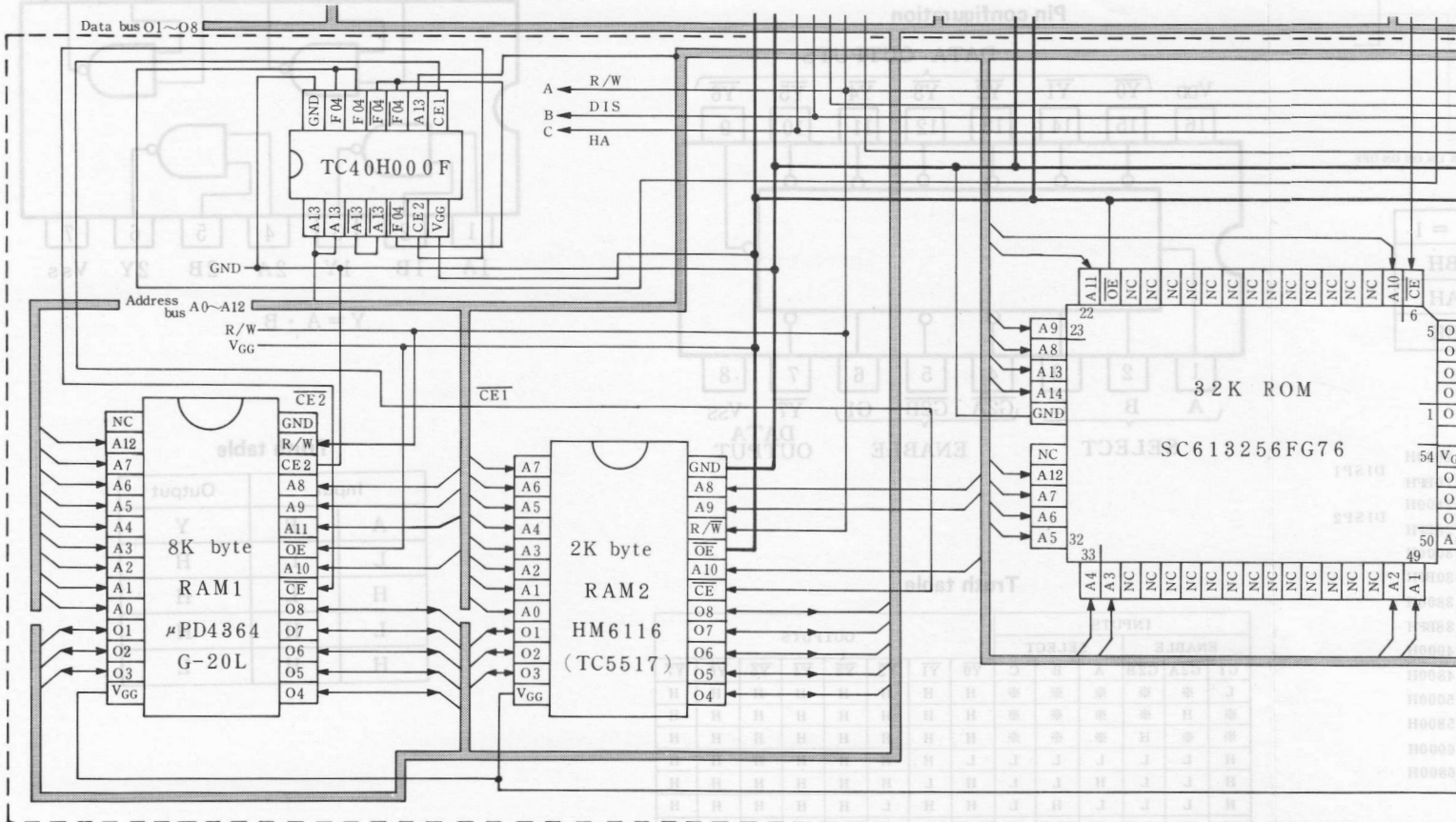

PES)

8-2. PC-1261 memory PWB (P-COS type)

ckaged  
116 or

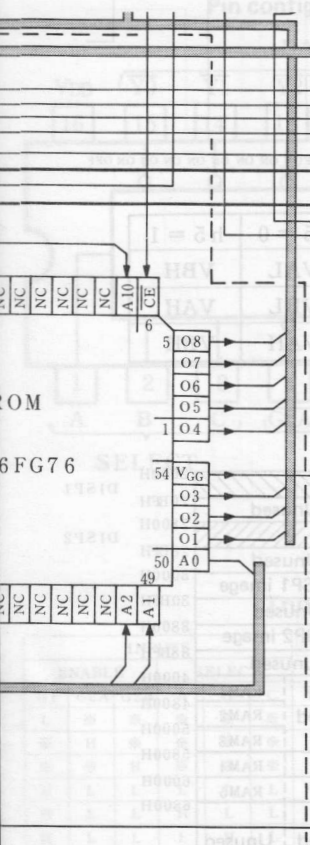
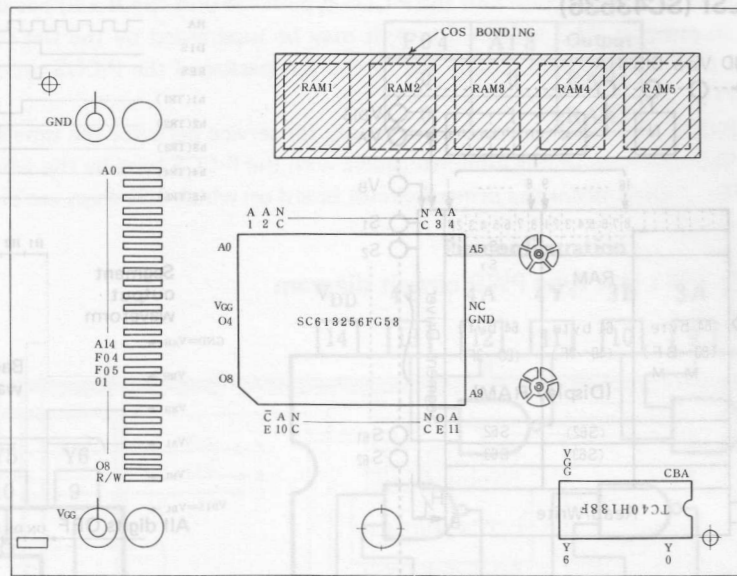

8-3. PC-1261 memory PWB (FLAT type)

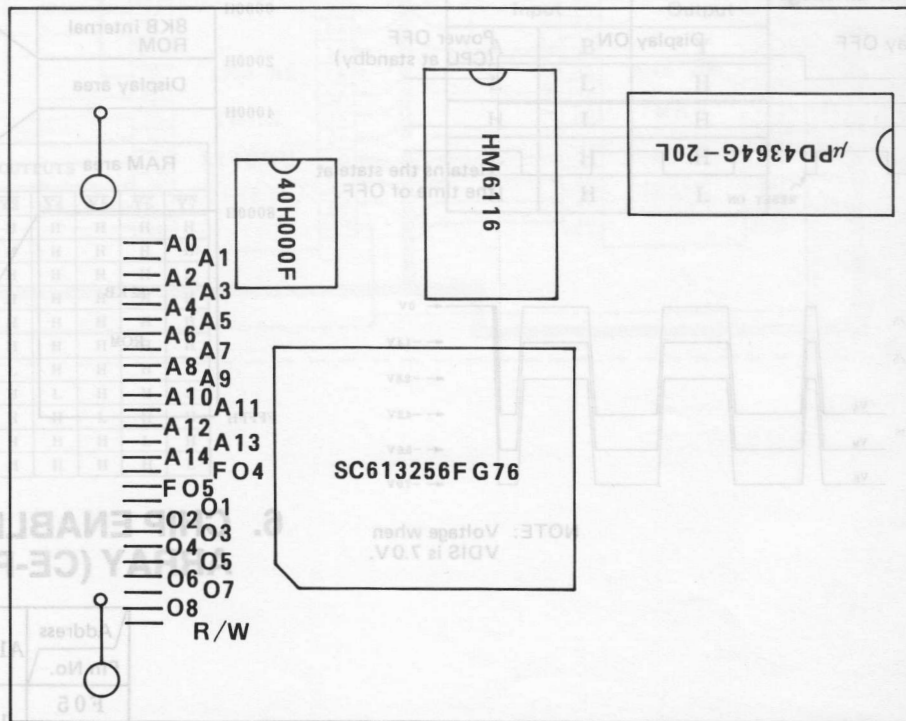

Address	A15	A14	A13	A12	A11
(ROM)	1	X	X	X	X
F04 (RAM)	0	1	X	X	X
F08 (Disp1)	0	0	1	X	0
B08 (Disp2)	0	0	1	X	1

X : Don't Care



# 9. CIRCUIT DIAGRAM

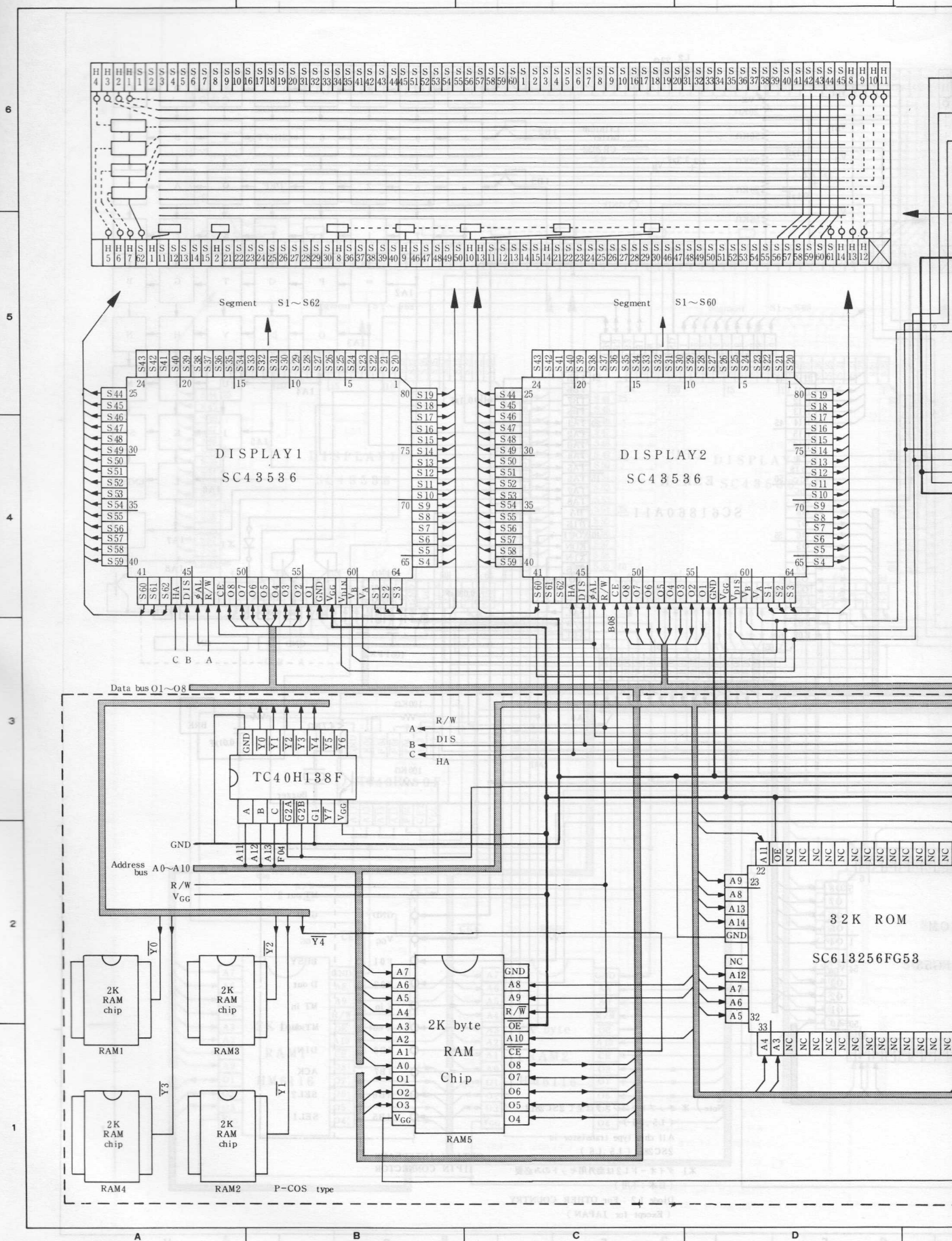

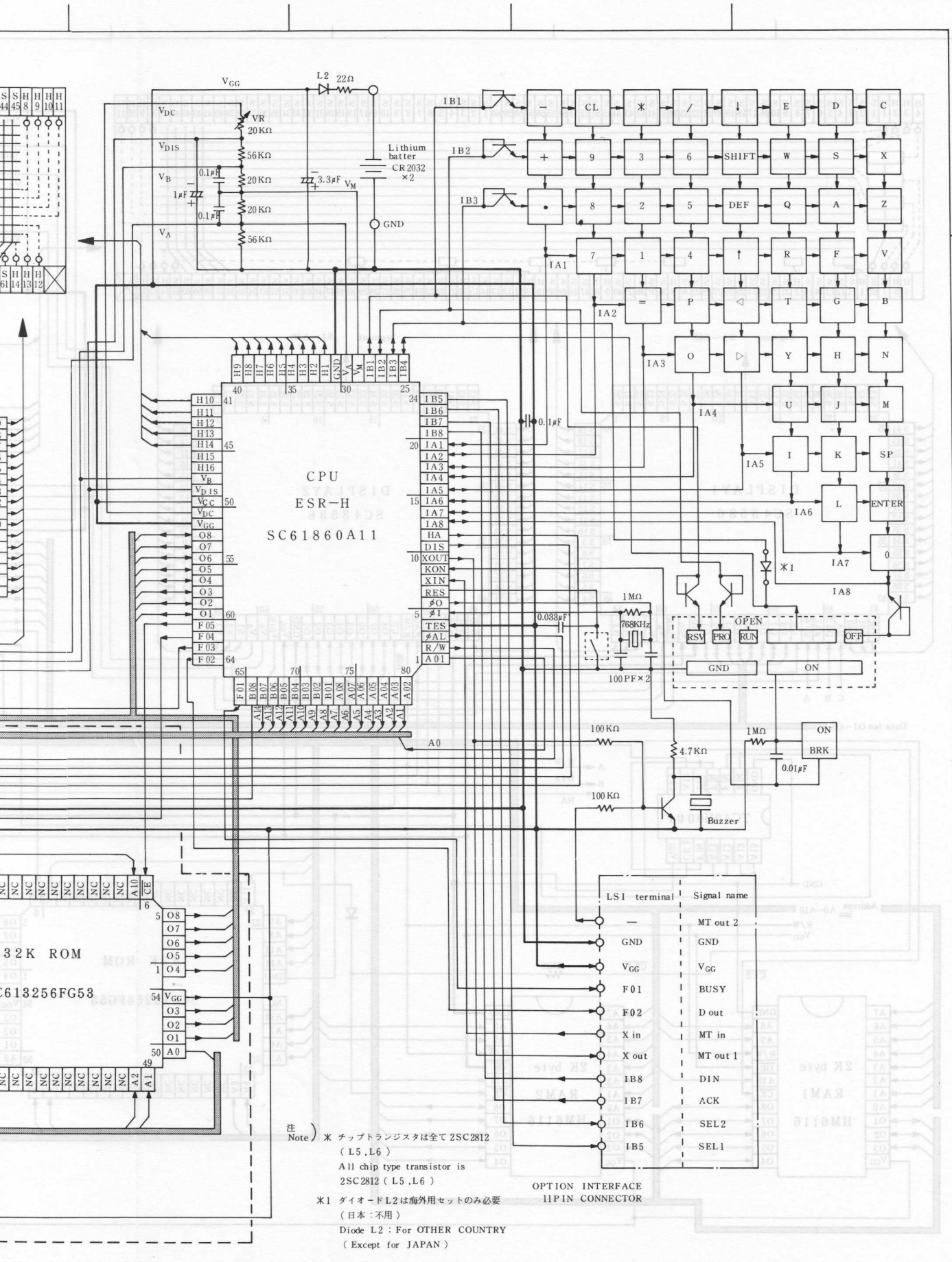

注) \* チップトランジスタは全て2SC2812 (L5, L6)  
A11 chip type transistor is 2SC2812 (L5, L6)  
\*1 ダイオードL2は海外用セットのみ必要 (日本: 不用)  
Diode L2: For OTHER COUNTRY (Except for JAPAN)

OPTION INTERFACE 11PIN CONNECTOR

LS1 terminal	Signal name
—	MT out 2
GND	GND
VGG	VGG
F 01	BUSY
F 02	D out
X in	MT in
X out	MT out 1
IB8	DIN
IB7	ACK
IB6	SEL 2
IB5	SEL 1



# 10. CIRCUIT DIAGRAM

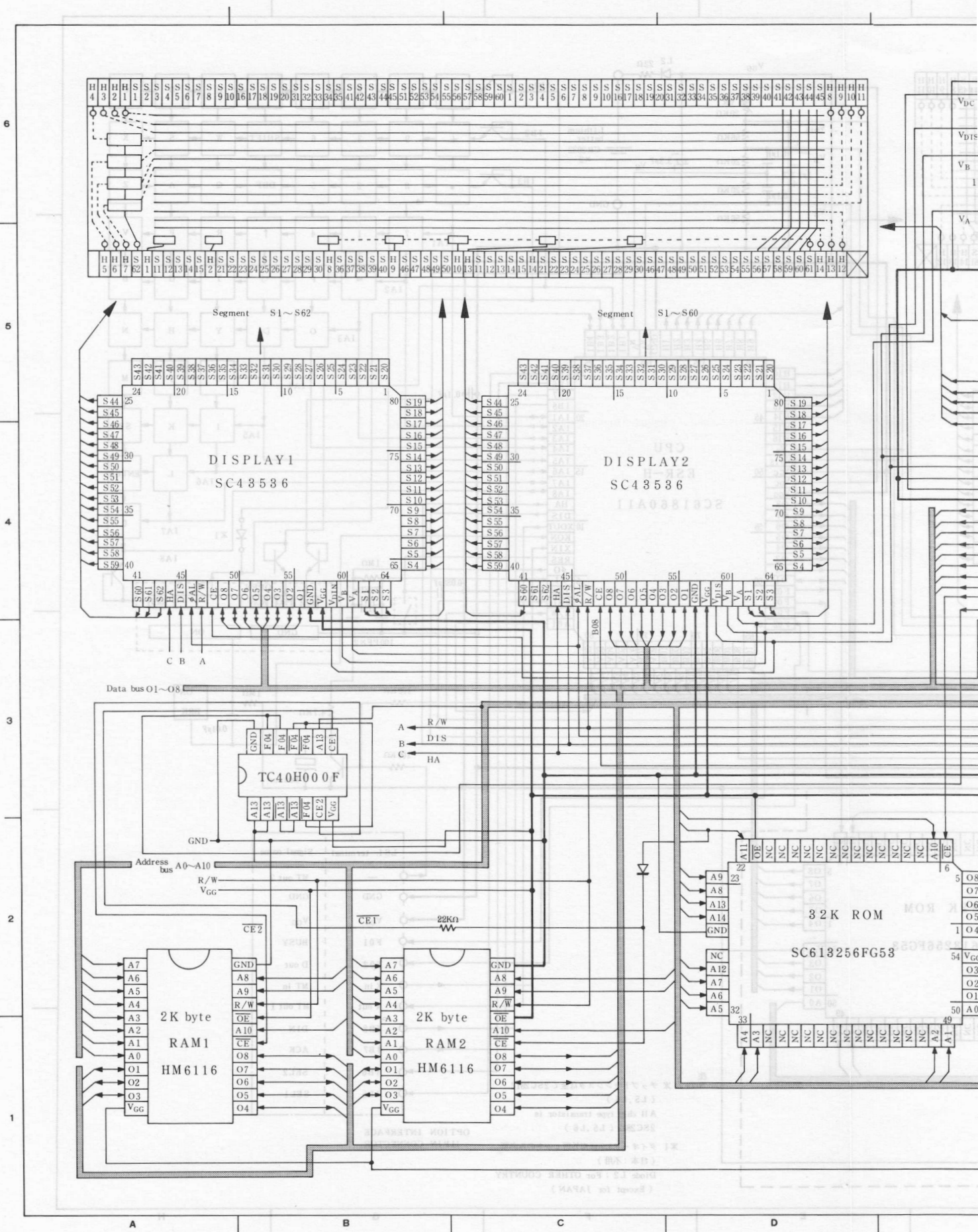

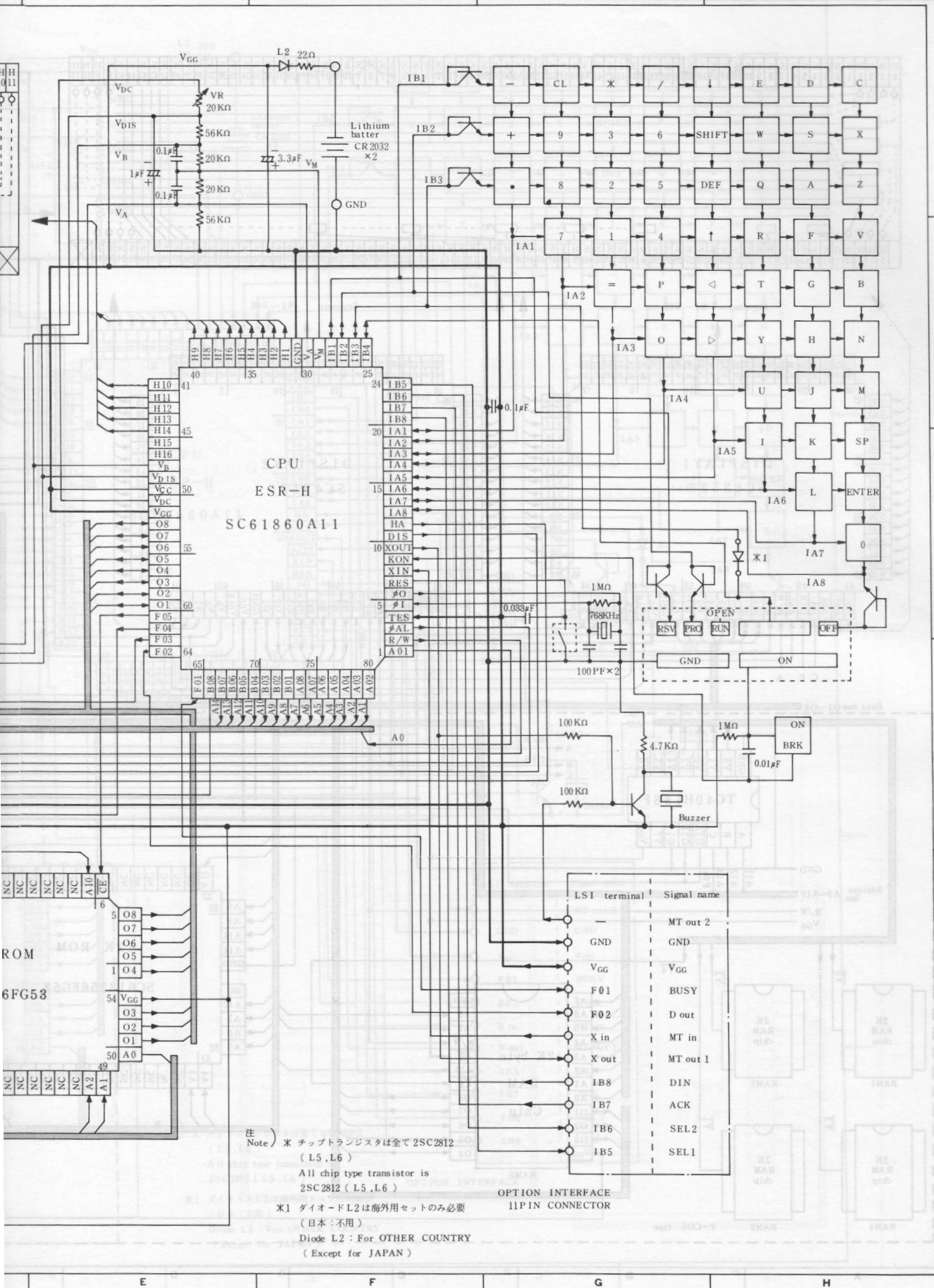

注) \* チップトランジスタは全て 2SC2812 (L5, L6)  
 All chip type transistor is 2SC2812 (L5, L6)  
 \*1 ダイオード L2 は海外用セットのみ必要 (日本: 不用)  
 Diode L2: For OTHER COUNTRY (Except for JAPAN)





11-2. PC-1260 memory PWB

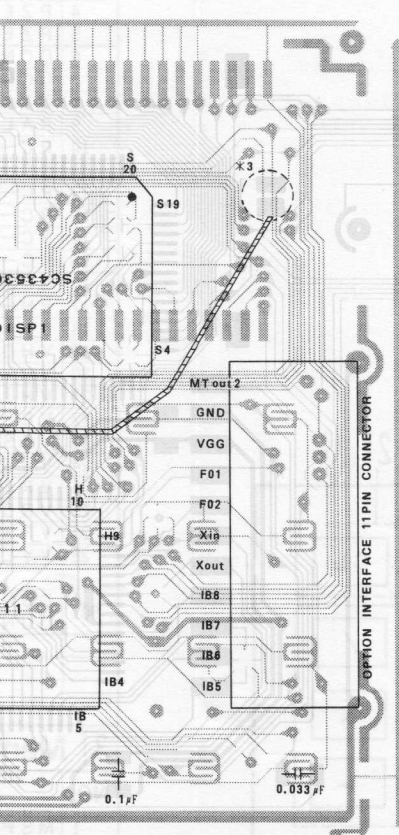
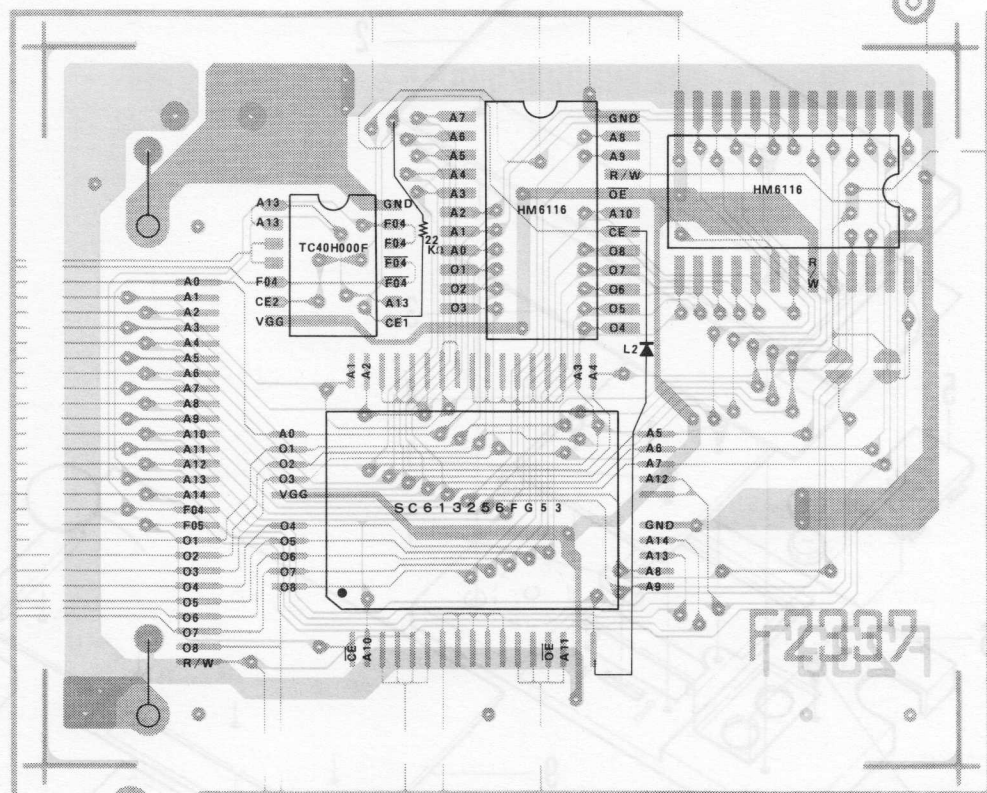
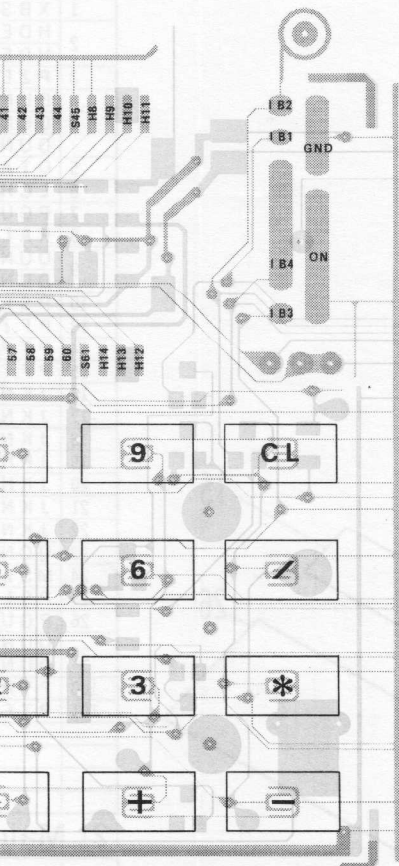

注)

- \* チップトランジスタは全て2SC2812 (L5, L6)  
All chip type transistor is 2SC2812 (L5, L6)
- \*1 ダイオードL2は海外用セットのみ必要 (日本: 不用)  
Diode L2: For OTHER COUNTRY (Except for JAPAN)
- \*2 ジャンパー線 (J1 及び J2) は日本のみ必要  
Jumper wire J1 and J2: For JAPAN only
- \*3, \*4 ハンダブリッジは海外用セットのみ必要 (日本: 不用)  
Solder bridge: For OTHER COUNTRY (Except for JAPAN)



\*5, \*6

Buzzer	生産 Production	
	PC-1260	PC-1261
*5 (RALMB1080CCZZ)	使用せず Not used	S. 59, 8月生産1~5000台のみ March 1984 Production (1~5000 sets only)
*6 (RALMB1080CC01)	S. 59, 8月生産1台目~ March 1984 Production (1 set ~)	S. 59, 8月生産5001台目~ March 1984 Production (5001 sets ~)



# 12. PARTS LIST & GUIDE

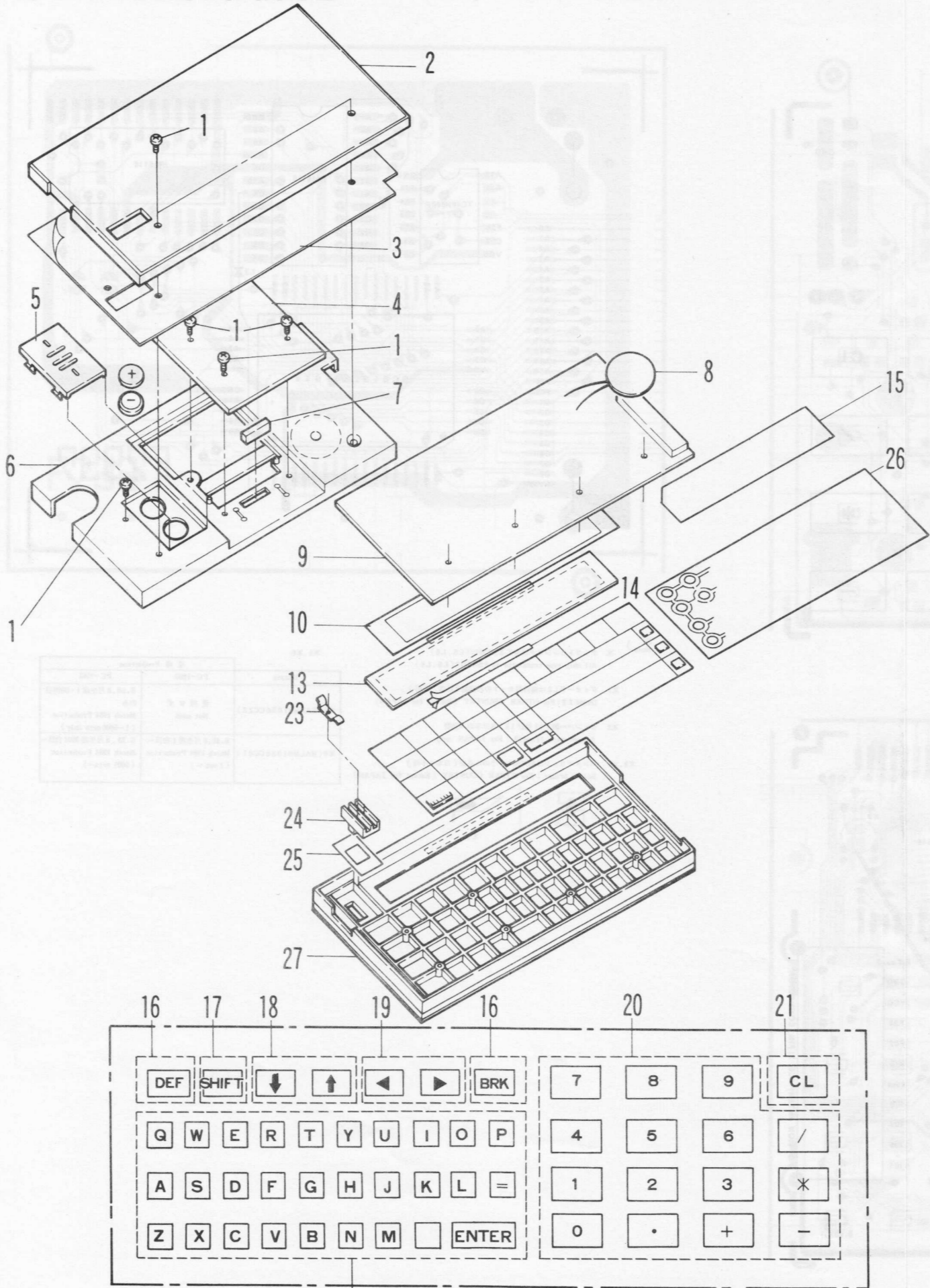

### 1 Ext

NO.	
1	XBS
2	HDE
3	PZE
4	DUN
5	QTA
6	LCH
7	PGU
8	RAL
9	DUN
10	PSL
13	PF i
14	PTP
15	PF i
16	JKN
17	JKN
18	JKN
19	JKN
20	JKN
21	JKN
22	JKN
23	QCN
24	MSL
25	PSL
26	PGU
27	DUN
100	PTP
101	PZE

### 2 Main

NO.	
1	LAN
2	PGU
3	PTP
4	PZE
5	PZE
6	QCN
7	QCN
8	QTA
9	RAL
10	RC-
11	RC-
12	RC-
13	RC-
14	RC-
15	RC-
16	RCR
17	RH-
18	RVR
19	VHD
20	VHi
21	VHi
22	VRS
23	VRS
24	VRS
25	VRS
26	VRS
27	VRS
28	VVL
901	DUN
	DUN

### 3 Mem

NO.	
1	MSP



### 1 Exteriors

NO.	PARTS CODE	PRICE RANK	NEW MARK	PART RANK	DESCRIPTION	PC 1260	PC 1261
1	XBSSC20P08000	AA		C	Screw (2x8)	○	○
2	HDECA2082CC18	AF	N	D	Bottom panel	○	○
	HDECA2082CC17	AF	N	D	Bottom panel	○	○
3	PZETL1491CCZZ	AC		C	Insulator sheet	○	○
4	DUNTK7997CCZZ	BQ	N	E	Memory PWB unit	○	○
	DUNTK7998CCZZ	BX	N	E	Memory PWB unit (P-COS type)	○	○
	DUNTK8189CCZZ	BX	N	E	Memory PWB unit (Flat type)	○	○
5	QTANZ1406CCZZ	AB		C	Battery terminal (⊕/⊖)	○	○
6	LCHSS1161CC01	AE	N	C	Chassis	○	○
7	PGUMS1540CCZZ	AC	N	C	Rubber connector	○	○
8	RALMB1030CC01	AD	N	B	Buzzer	○	○
9	DUNTK7939CCZZ	BR	N	E	Main PWB unit	○	○
	DUNTK7941CCZZ	BR	N	E	Main PWB unit	○	○
10	PSLDP1463CC01	AC	N	C	Display mask	○	○
13	PFLW1513CCZZ	AC	N	C	Acryl filter	○	○
14	PTPEH1039CCZZ	AA		C	Adhesive tape	○	○
15	PFLW1424CCZZ	AD		C	Polarized filter	○	○
16	JKNBZ1604CC11	AH		C	Key top (DEF·BRK key each of 24pcs/1set)	○	○
17	JKNBZ1606CC02	AF		D	Key top (SHIFT key 48pcs/1set)	○	○
18	JKNBZ1604CC12	AH		C	Key top (↑·↓ key 24pcs/1set)	○	○
19	JKNBZ1604CC13	AH		C	Key top (▶·◀key 24pcs/1set)	○	○
20	JKNBZ1492CC09	AF		C	Key top (Key top for 15keys each of 1pc)	○	○
21	JKNBZ1622CC02	AE		D	Key top (CL key 20pcs/1set)	○	○
22	JKNBZ1794CC01	AG		C	Key top (Type writer key each of 1pc)	○	○
23	QCNTM1042CCZZ	AA		C	Slide switch terminal	○	○
24	MSLIP1020CC01	AB		C	Slider	○	○
25	PSLDP1318CCZZ	AA		C	Shield plate	○	○
26	PGUMM1426CCZZ	AH		B	Key rubber	○	○
27	DUNTG7936CCZZ	AP	N	D	Top cabinet unit	○	○
	DUNTG7937CCZZ	AP	N	D	Top cabinet unit	○	○
100	PTPEH1090CCZZ	AA		C	Adhesive tape	○	○
101	PZETL1465CCZZ	AA		C	Insulator	○	○

### 2 Main PWB unit

NO.	PARTS CODE	PRICE RANK	NEW MARK	PART RANK	DESCRIPTION	PC 1260	PC 1261
1	LANGK1535CCZZ	AC		C	LCD angle	○	○
2	PGUMS1546CCZZ	AD	N	C	Rubber connector	○	○
3	PTPEH1195CCZZ	AA		C	LCD tape	○	○
4	PZETL1313CCZZ	AA		C	Spacer (Round)	○	○
5	PZETL1353CCZZ	AA		C	Spacer (Square)	○	○
6	QCNCW1306CC1B	AK		C	Connector (12pin)	○	○
7	QCNTM1051CCZZ	AB		C	Reset terminal	○	○
8	QTANZ1289CCZZ	AB		C	Battery terminal	○	○
9	RALMB1030CC01	AD	N	B	Buzzer	○	○
10	RC-CZ1021CCN1	AB		C	Capacitor (0.1μF)	○	○
11	RC-CZ1035CCN1	AB		C	Capacitor (100pF)	○	○
12	RC-CZ1037CCN1	AB		C	Capacitor (0.01μF)	○	○
13	RC-CZ1047CCN1	AB		C	Capacitor (0.033μF)	○	○
14	RC-SZ1007CCZZ	AF		C	Capacitor (1μF)	○	○
15	RC-SZ1021CCZZ	AC		C	Capacitor (10WV 3.3μF)	○	○
16	RCRSZ1063CCZZ	AF		B	Crystal (768KHz)	○	○
17	RH-iX1012CCN1	AC		B	Transistor (C2812,L5 L6)	○	○
18	RVR-Z2400QCZZ	AF		C	Variable resistor	○	○
19	VHDDS1588L2-1	AB		B	Diode (DS1588L2)	○	○
20	VHISC43536/-1	AX		B	IC (SC43536)	○	○
21	VHISC61860A11	BB	N	B	IC (SC61860A11)	○	○
22	VRS-TP2BD104J	AA		C	Resistor (1/8W 100KΩ ±5%)	○	○
23	VRS-TP2BD105J	AA		C	Resistor (1/8W 1.0MΩ ±5%)	○	○
24	VRS-TP2BD220J	AA		C	Resistor (1/8W 22Ω ±5%)	○	○
25	VRS-TP2BD203J	AA		C	Resistor (1/8W 20KΩ ±5%)	○	○
26	VRS-TP2BD472J	AA		C	Resistor (1/8W 4.7KΩ ±5%)	○	○
27	VRS-TP2BD563J	AA		C	Resistor (1/8W 56KΩ ±5%)	○	○
28	VVLLF8223E/-1	AX	N	B	LCD	○	○
	(Unit)						
901	DUNTK7939CCZZ	BR	N	E	Main PWB unit	○	○
	DUNTK7941CCZZ	BR	N	E	Main PWB unit	○	○

### 3 Memory PWB unit

NO.	PARTS CODE	PRICE RANK	NEW MARK	PART RANK	DESCRIPTION	PC 1260	PC 1261
1	MSPRC1207CCZZ	AB		C	Spring	○	○

3 Memory PWB unit

NO.	PARTS CODE	PRICE RANK	NEW MARK	PART RANK	DESCRIPTION	PC 1260	PC 1261
2	VHiHM6116//—C	AZ		B	IC (HM6116)	○	
3	VHiTC40H000FN	AG		B	IC (TC40H000FN)	○	
4	VHiTC40H138FN	AQ		B	IC (TC40H138FN)		○
5	VHi613256FG53	BD	N	B	IC (SC613256FG53)	○	○
	VHi613256FG76	BD	N	B	IC <For flat type memory PWB> (SC613256FG76)		○
6	VHiD4364G20LN	BR	N	B	IC <For flat type memory PWB> (UPD4364G-20L)		○
7	VRS-TP2BD223J	AA		C	Resistor (1/8W 22KΩ ±5%)	○	
8	VS2SC2812-H-1	AB		B	Transistor (2SC2812-H)	○	
9	VRD-ST2BY223J	AA		C	Resistor (1/8W 22KΩ ±5%)	○	○
10	VHDDS1588L2-1	AB		B	Diode (DS1588L2)	○	○
	(Unit)						
901	DUNTK7997CCZZ	BQ	N	E	Memory PWB unit	○	
	DUNTK7998CCZZ	BX	N	E	Memory PWB unit (P-COS type)		○
	DUNTK8189CCZZ	BX	N	E	Memory PWB unit (Flat type)		○

4 Accessory

NO.	PARTS CODE	PRICE RANK	NEW MARK	PART RANK	DESCRIPTION	PC 1260	PC 1261
1	GCASP1099CCZZ	AE	N	D	Hard case	○	○
2	LPLTP1099CCZZ	AA		C	Ten plate	○	○
3	TiNSE4170CCZZ	AW	N	D	Instruction book (USA)	○	○
	TiNSG4175CCZZ	AX	N	D	Instruction book (Germany)	○	○
	TiNSE4171CCZZ	AX	N	D	Instruction book (Other countries)	○	○
4	TLABZ1295CCZZ	AA		D	Name label	○	○
5	TLABH1997CCZZ	AC	N	C	Operation label	○	○
6	SPAKA7413CCZZ	AE		D	Packing cushion for set	○	○
7	SPAKC8635CCZZ	AD	N	D	Packing case	○	
	SPAKC8627CCZZ		N	D	Packing case		○

# SHARP

SHARP CORPORATION  
Industrial Instruments Group  
Reliability & Quality Control Department  
Yamatokoriyama, Nara 639-11, Japan

1984 July Printed in Japan ©